



INSTALLATION 223039/223039-2 (2009 FORD F-150 CREW CAB)

PARTS LIST

- (1) ARIES OVAL (DRIVER SIDE)
- (1) ARIES OVAL (PASSENGER SIDE)
- (2) FRONT MOUNT BRACKETS
- (2) BACK MOUNT BRACKETS (**NOTE: THESE TWO BRACKETS ARE 5/8" LONGER**)
- (8) 10MM CLIP NUTS
- (8) 10MM X 25MM HEX HEAD BOLTS
- (8) 10MM SAE FLAT WASHERS
- (24) 10MM FLAT WASHERS
- (16) 10MM X 30MM HEX HEAD BOLTS

PROCEDURE

1. BEGIN INSTALLATION BY WORKING ON PASSENGER SIDE OF VEHICLE
2. REMOVE FACTORY LONG GATE RUBBER PLUG/TAPE WHICH COVERS MOUNTING HOLES ON INNER ROCKER PANEL LOCATED IN FRONT AND REAR (SEE DIAGRAM 1.). ONCE REMOVED SLIDE 10MM CLIP NUTS OVER HOLES (THERE ARE TWO HOLES FOR EACH BRACKET).
3. INSTALL MOUNTING BRACKETS TO INNER ROCKER PANEL USING 10MM BOLTS AS SHOWN IN DIAGRAM 2. HAND TIGHTEN ONLY.
4. ATTACH SIDEBAR TO BRACKETS USING THE 10MM HEX HEAD BOLTS AND WASHERS. ALIGN THE SIDE BAR WITH THE VEHICLE BODY THEN TIGHTEN ALL FASTENERS AT 30FT/LBS). REPEAT STEPS FOR PASSENGER SIDE TO COMPLETE INSTALLATION.

DIAGRAM 1



DIAMGRAM 2



DIAGRAM 3

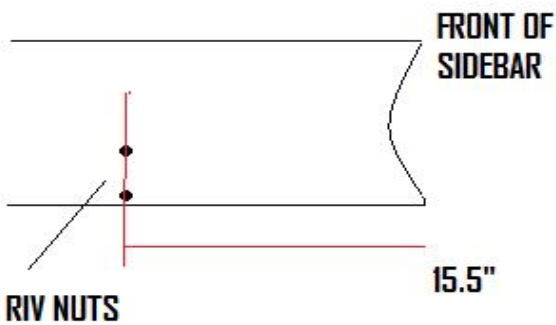
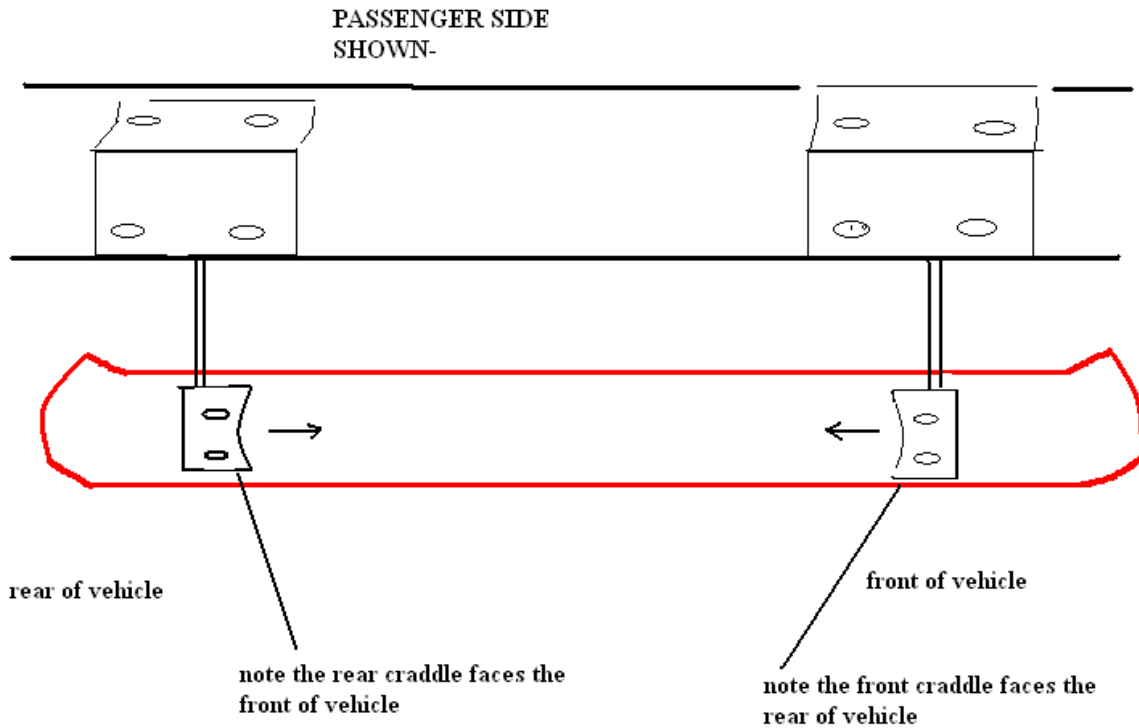

NOTE: TO ESTABLISH FRONT OF THE SIDEBAR- AT THE BOTTOM OF THE TUBE YOU WILL HAVE THE RIV NUTS 15.5" FROM THE END. THE TUBE WILL FACE INWARD.

FINISH PROTECTION- ARIES PRODUCTS HAVE A HIGH FINISH THAT MUST BE MAINTAINED SUCH AS ANY OTHER HIGH FINISH PRODUCT ON THE VEHICLE. PROTECT THE FINISH WITH A NON-ABRASIVE AUTOMOTIVE WAX. THE USE OF SOAP, POLISH, OR WAX THAT CONTAINS ABRASIVES IS DETRIMENTAL, AS THE COMPOUNDS SCRATCH THE FINISH AND OPEN IT TO CORROSION.

DISCLAIMER- BUYER ASSUMES ALL RISK AND LIABILITY WHATSOEVER FROM THE INSTALLATION AND USE OF ARIES PRODUCTS. ARIES PRODUCTS ARE SOLD AS DECORATIVE ACCESSORIES AND SHOULD NOT BE RELIED UPON AS PROTECTION FOR THE VEHICLE OR OCCUPANTS IN THE EVENT OF A COLLISION OR ROLL OVER. ARIES AUTOMOTIVE ASSUMES NO LIABILITY FOR INJURY, LOSS, INCIDENTAL OR CONSEQUENTIAL DAMAGES IN THE EVENT OF A COLLISION OR ROLLOVER