



## INSTALLATION INSTRUCTIONS

**BULL BAR PART #35-3007/B35-3007**

**04-08 FORD F-150 2/4 WHEEL DRIVE**

**/ 06-07 LINCOLN MARK LT/07-08 FORD EXPEDITION**

### PARTS LIST:

1	Bull Bar	4	12mm Flat Washers
1	Driver/Left Mounting Bracket	4	12mm Lock Washers
1	Passenger/Right Mounting Bracket	4	12mm Hex Nuts
4	12mm Bolt Plates	8	10-1.50mm x 30mm Hex Head Bolts
		14	10mm Flat washers
		8	10mm Lock Washers
		6	10mm Hex Nuts

### PROCEDURE:

1. REMOVE CONTENTS FROM BOX. VERIFY ALL PARTS ARE PRESENT. READ INSTRUCTIONS CAREFULLY BEFORE STARTING INSTALLATION.
2. **NOTE:** It may be necessary to remove/relocate front license plate and license plate bracket. It is not required, but strongly recommended. If local/state law requires a license plate, license plate relocation kit is available through your local retailer store.

#### Vehicles with Factory Tow Hooks

3. Remove tow hooks by removing the front bolt and loosening rear bolt. Slide tow hooks off. Remove rear bolt and make sure nut plate in frame stays aligned with holes.
4. Position Bottom Brackets up to bottom frame and secure them with factory tow hook bolts (**Figure 1**).

#### Vehicles without Tow Hooks

5. Insert two bolt plates through the end of frame and into bottom frame holes. **NOTE:** It may be necessary to remove the lower plastic portion of the bumper to gain access to ends of frame rails. The indented pockets in the lower bumper will need to be cut out to allow bottom brackets to pass trough.
6. Position Bottom Brackets up to bottom frame and trough Bolt Plates and secure them with the included (4) 12mm Flat Washers, (4) 12mm Lock Washers, and (4) Hex Nuts (**Figure 2**).
7. Position Bull Bar on the outer side of Mounting Brackets. Attach Bull Bar to Mounting Brackets using the included (4) 10mm x 30mm Hex Head Bolts, (4) 10mm Lock Washers, (4) 10mm Hex Nuts, and (8) 10mm Flat Washers.
8. Adjust Bull Bar properly, and then tighten all hardware at this time.
9. Do periodic inspections to the installation to make sure that all hardware is secure and tight.

**To protect your investment**, wax this product after installing. Regular waxing is recommended to add a protective layer over the finish. Do not use any type of polish or wax that may contain abrasives that could damage the finish.

**For stainless steel:** Aluminum polish may be used to polish small scratches and scuffs on the finish. Mild soap may be used also to clean the Sidebar.

**For gloss black finishes:** Mild soap may be used to clean the Sidebar.

**(Driver Side Installation Shown - With Tow Hooks Equipped)**

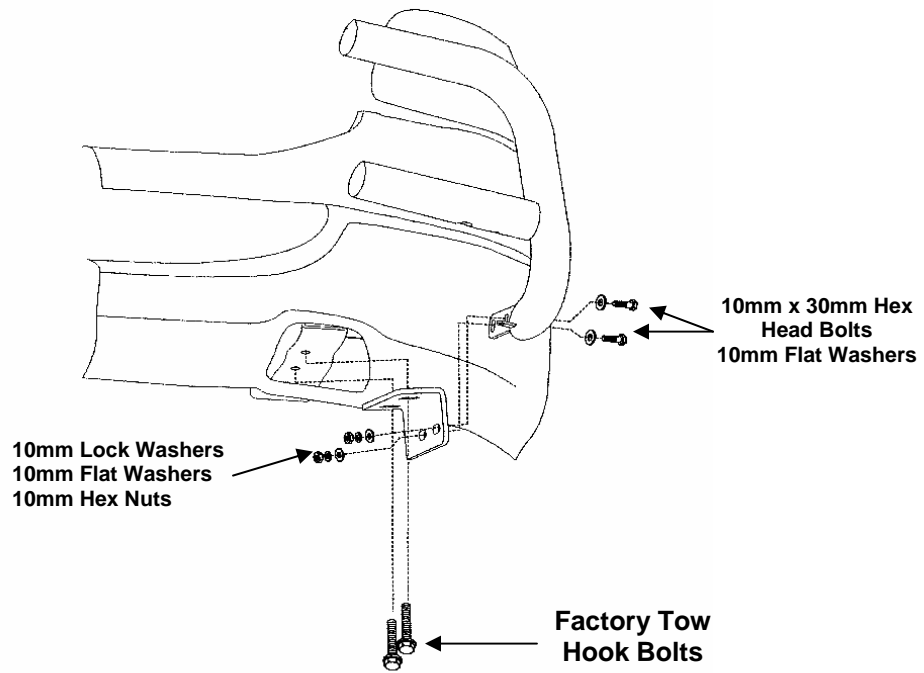

**Figure 1**

**(Driver Side Installation Shown - Without Tow Hooks)**

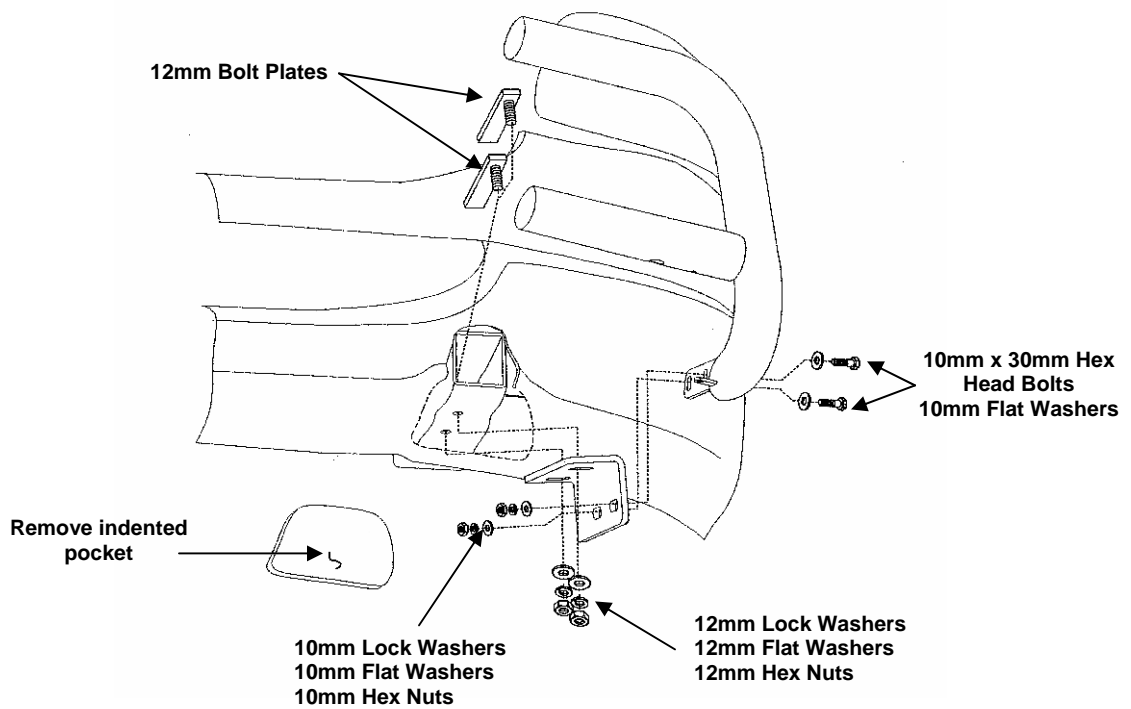

**Figure 2**